

The SL6140 is an integrated broadband AGC amplifier, designed on an advanced bipolar process. The amplifier provides over 15dB of linear gain into 50 Ω at 400MHz. Gain control is also provided with over 70dB of dynamic range. The SL6140 offers over 45dB of voltage gain with an R_L of 1k Ω .

FEATURES

- 400MHz Bandwidth ($R_L=50 \Omega$)
- High voltage Gain 45dB ($R_L=1k \Omega$)
- 70dB Gain Control Range
- High Output Level at Low Gain
- Surface Mount Plastic Package
- Low Cost

APPLICATIONS

- RF/IF Amplifier
- High Gain Mixers
- Video Amplifiers

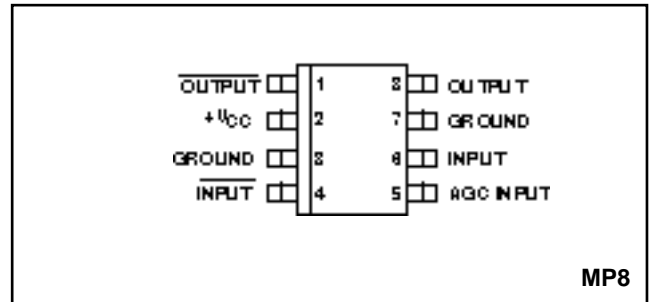

Fig.1 Pin connections top view

ORDERING INFORMATION

- | | |
|----------------|---|
| SL6140/NA/MP | Industrial temperature range miniature plastic package. |
| SL6140/NA/MPTC | Tape and Reel |

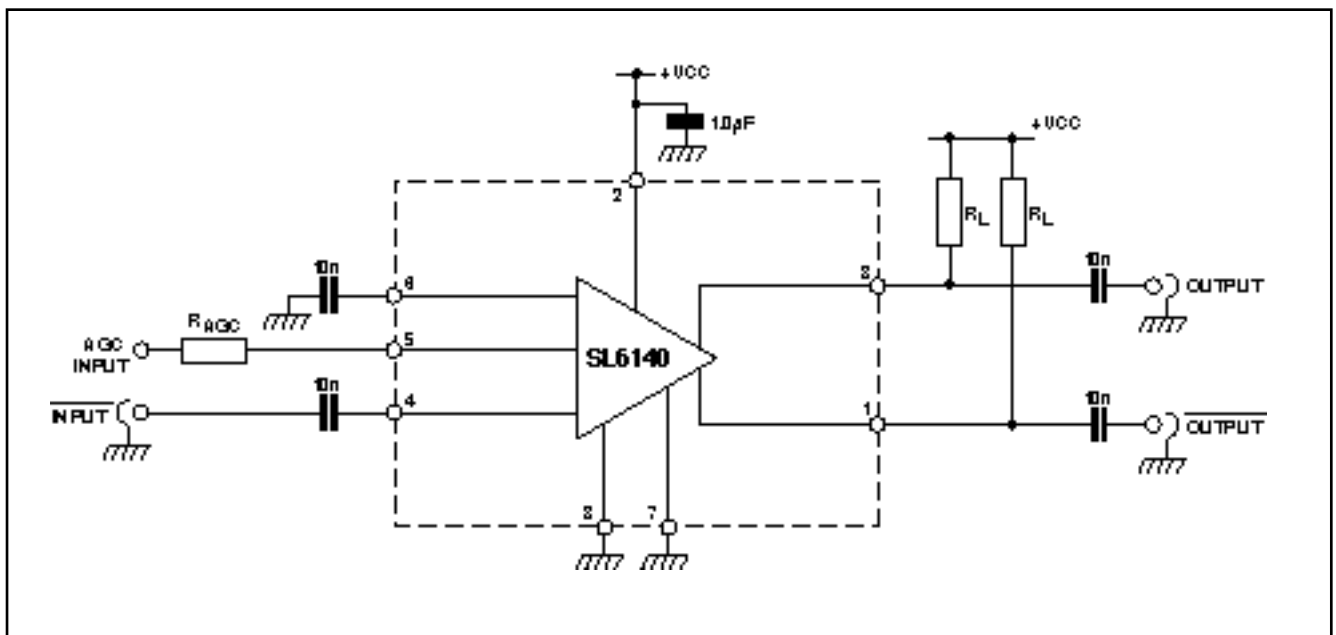

Fig.2 Typical application

SL6140

ELECTRICAL CHARACTERISTICS

These characteristics are guaranteed over the following conditions (unless otherwise stated)

$T_{amb} = 25^{\circ}\text{C}$, $V_{CC} = 12\text{V} + 5\%$, $V_{IN} = 1\text{mV}_{\text{RMS}}$, Frequency = 6MHz, Load (R_L) = 10KOHms, $R_{AGC} = 22\text{KOHm}$

Characteristic	Pin	Value			Units	Conditions
		Min	Typ	Max		
Supply current	5,6,7		19	23	mA	No input signal
Output stage current	5,6 (sum)	5	7	9	mA	No input signal
Output current matching (magnitude of difference of output currents)	5,6		1.0		mA	See Note 2
AGC range	2	60	75		dB	See Fig. 4 & Note 1 ($V_{AGC} = 0\text{V}$ to 10V)
Voltage gain (single ended)	5,6	40	45 55		dB	$R_L = 1\text{k}$ See Fig. 5 & Note 1 Tuned input and output
	5,6		15		dB	$R_L = 50$
Bandwidth (-3dB)	5,6		25 400		MHz	$R_L = 1\text{k}$ See Fig. 5. See Note 2 $R_L = 50$
Maximum output level (single ended)	0dB AGC	5,6	3.5		V p-p	Note 1
	-30dB AGC	5,6	3.5		V p-p	$R_L = 1\text{k}$. Note 1
Noise figure	5,6		5		dB	Test CCT Fig. 13

Note. 1 Guaranteed but not tested.

DESCRIPTION

The SL6140 (Fig. 3) is a high gain amplifier with an AGC control capable of reducing the gain of the amplifier by over 70dB. The gain is adjustable by applying a voltage to the AGC input via an external resistor (R_{AGC}), the value of which adjusts the curve of gain reduction versus control voltage (see Fig. 4). As the output stage of the amplifier is an open collector the maximum voltage gain is determined by R_L . With load resistance of 1k the single ended voltage gain is 45dB and with a load resistance of 50 the voltage gain is 15dB ($20\log_{10} V_{OUT}/V_{IN}$). Another parameter that depends on the load resistance is the bandwidth: 25MHz for $R_L = 1\text{k}$, as compared with 400MHz for $R_L = 50$. R_L is chosen to give either the required bandwidth or voltage gain for the circuit.

Figs. 7 through to 10 show the typical S parameters for the device. Figs. 11 and 12 show the typical variation in 3rd order intercept performance with AGC.

In any application, the substrate should be connected to the most negative point in the circuit, usually to the same point as pin 3.

ABSOLUTE MAXIMUM RATINGS

Supply voltage, V_{CC}	+18V
Input voltage (differential)	+5V
AGC supply	V_{CC}
Storage temperature	-55°C to +150°C
Operating temperature range	
SL6140 MP	-40°C to +85°C at 200mW
Chip operating temperature	
SL6140 MP	+150°C

THERMAL RESISTANCE

Chip-to-ambient	
SL6140 MP	163°C/W
Chip-to-case	
SL6140 MP	57°C/W

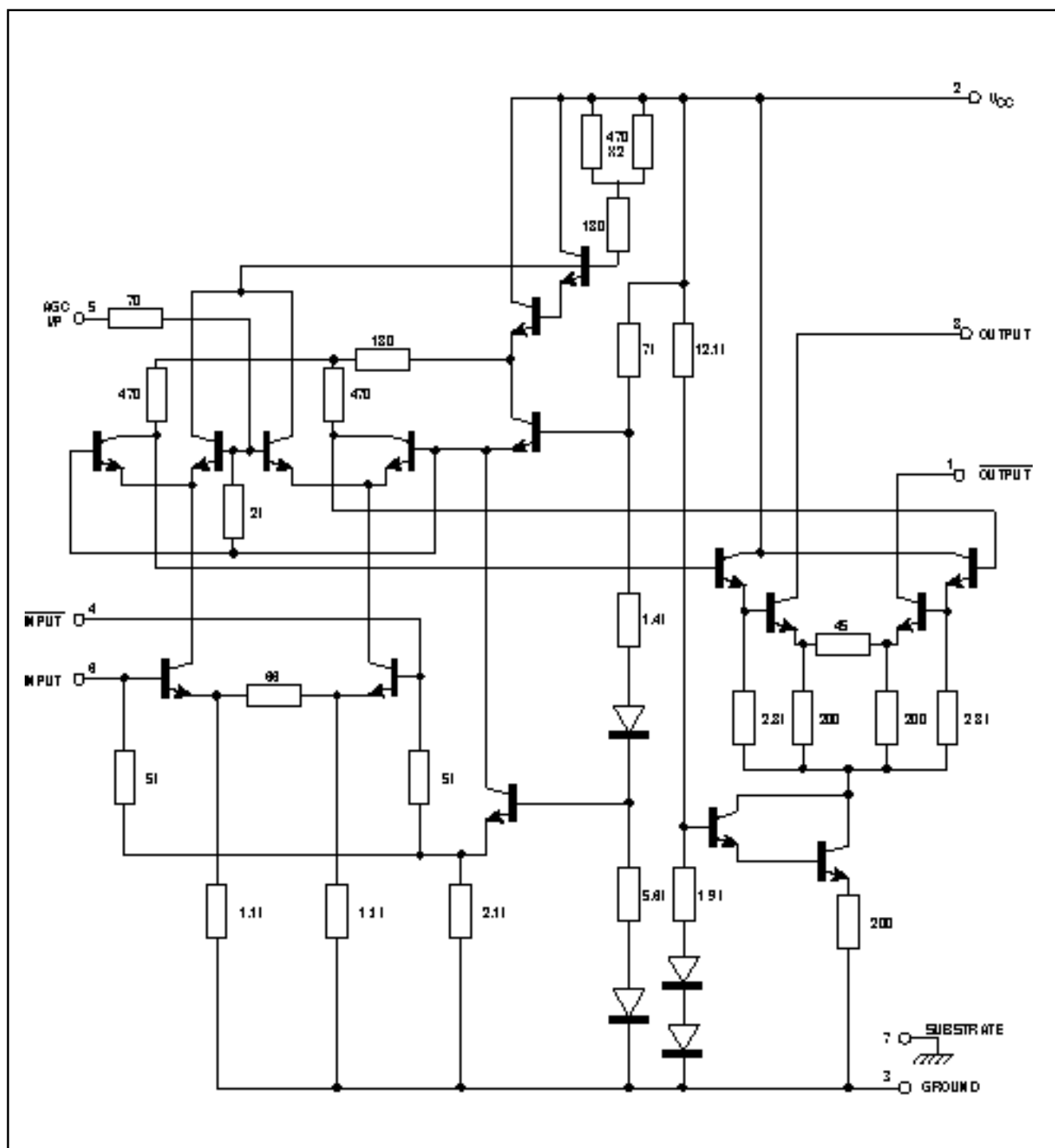

Fig. 3 Full circuit diagram of SL6140

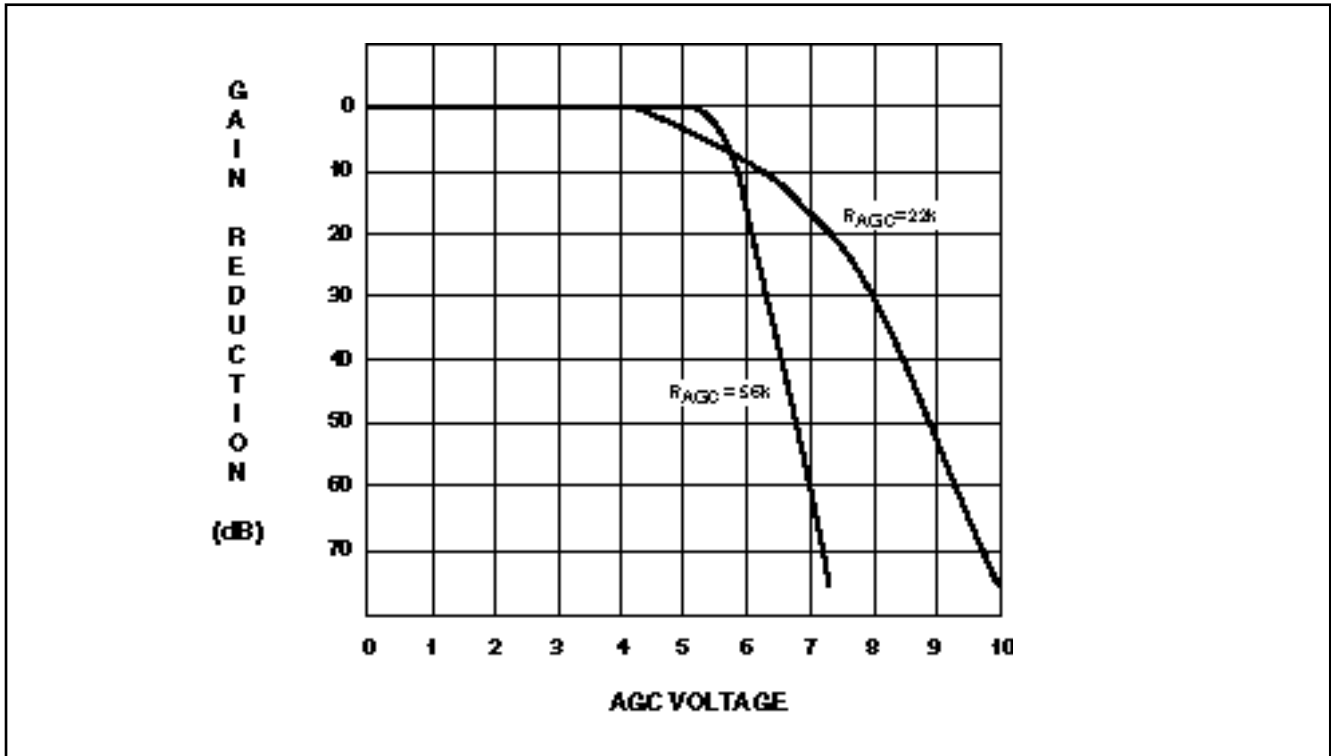

Fig. 4 Gain reduction v. AGC voltage

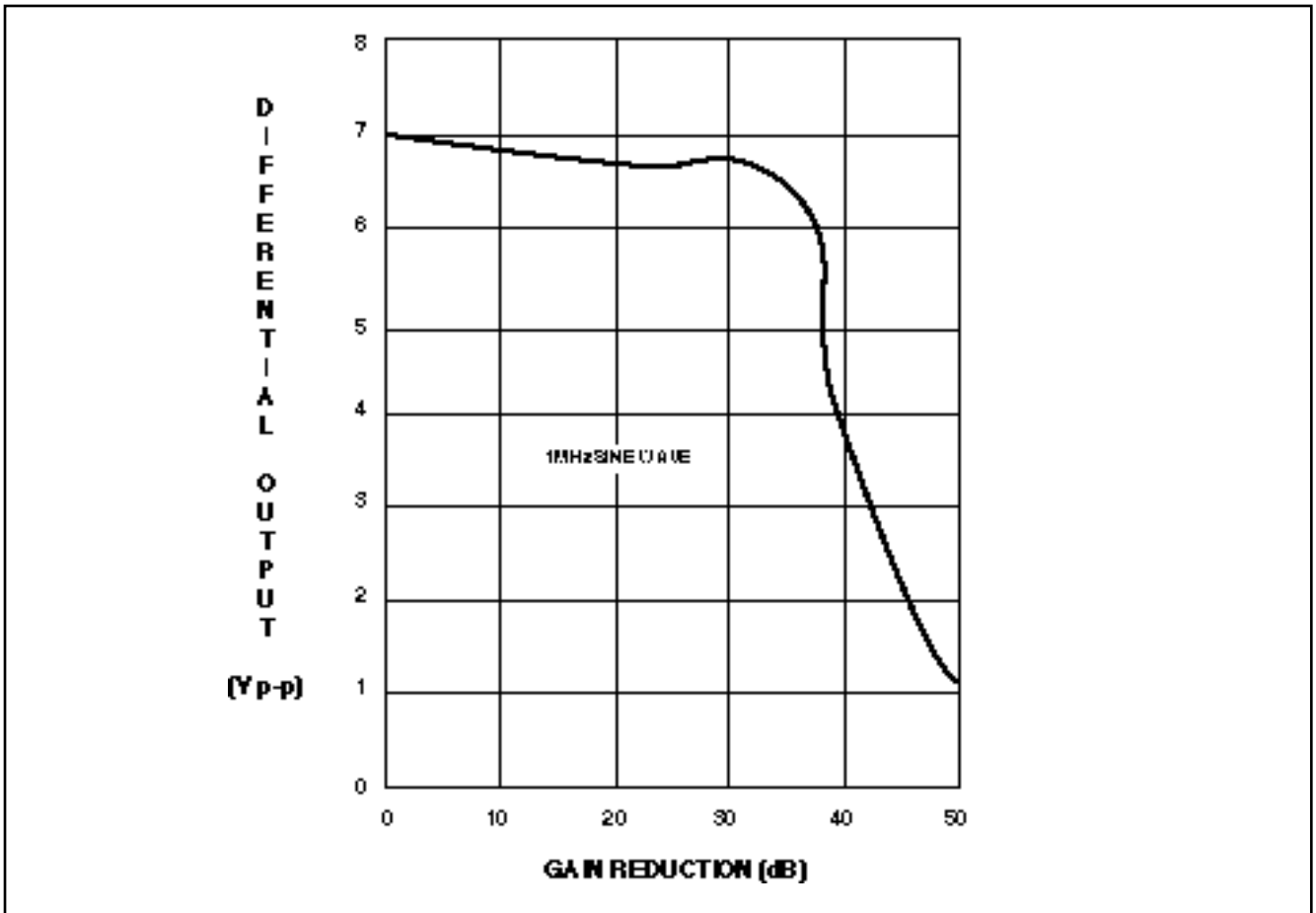

Fig. 5 Max differential O/P voltage v. gain reduction

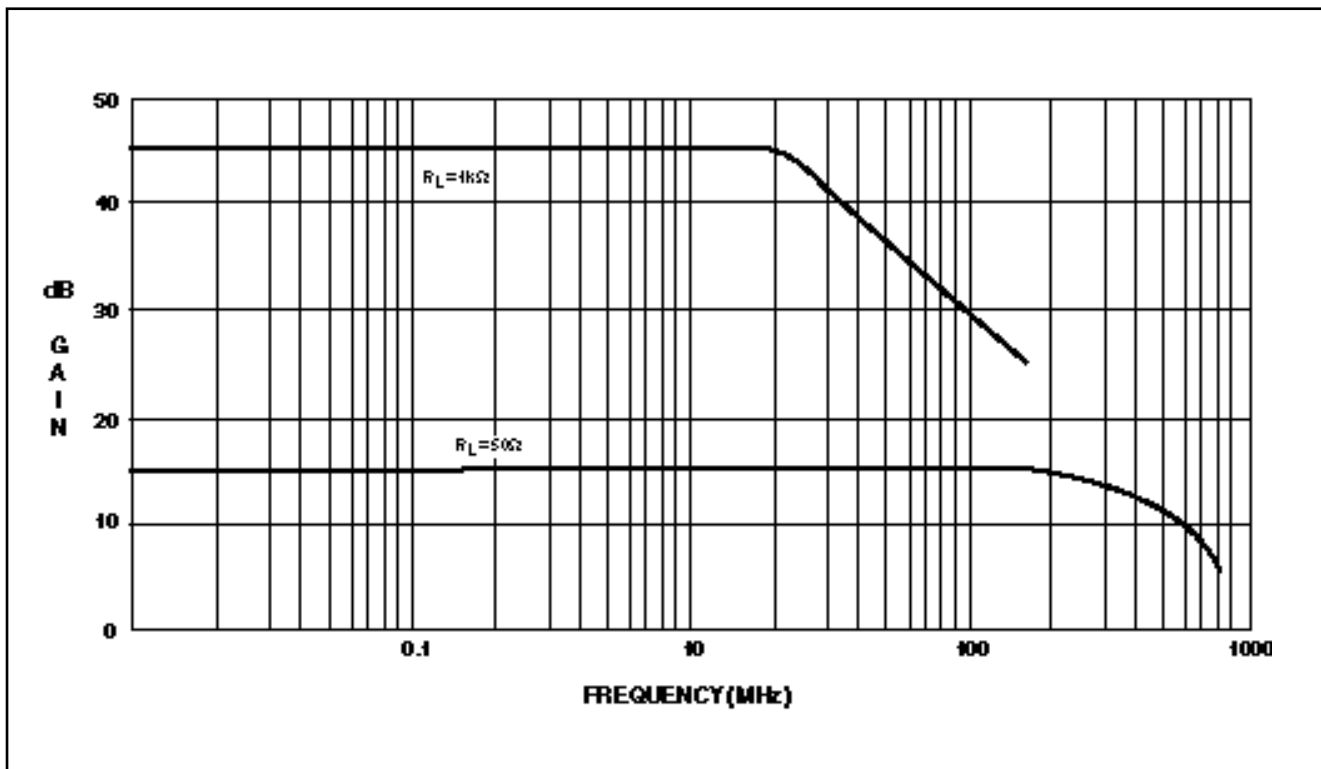

Fig. 6 Voltage Gain v. Frequency

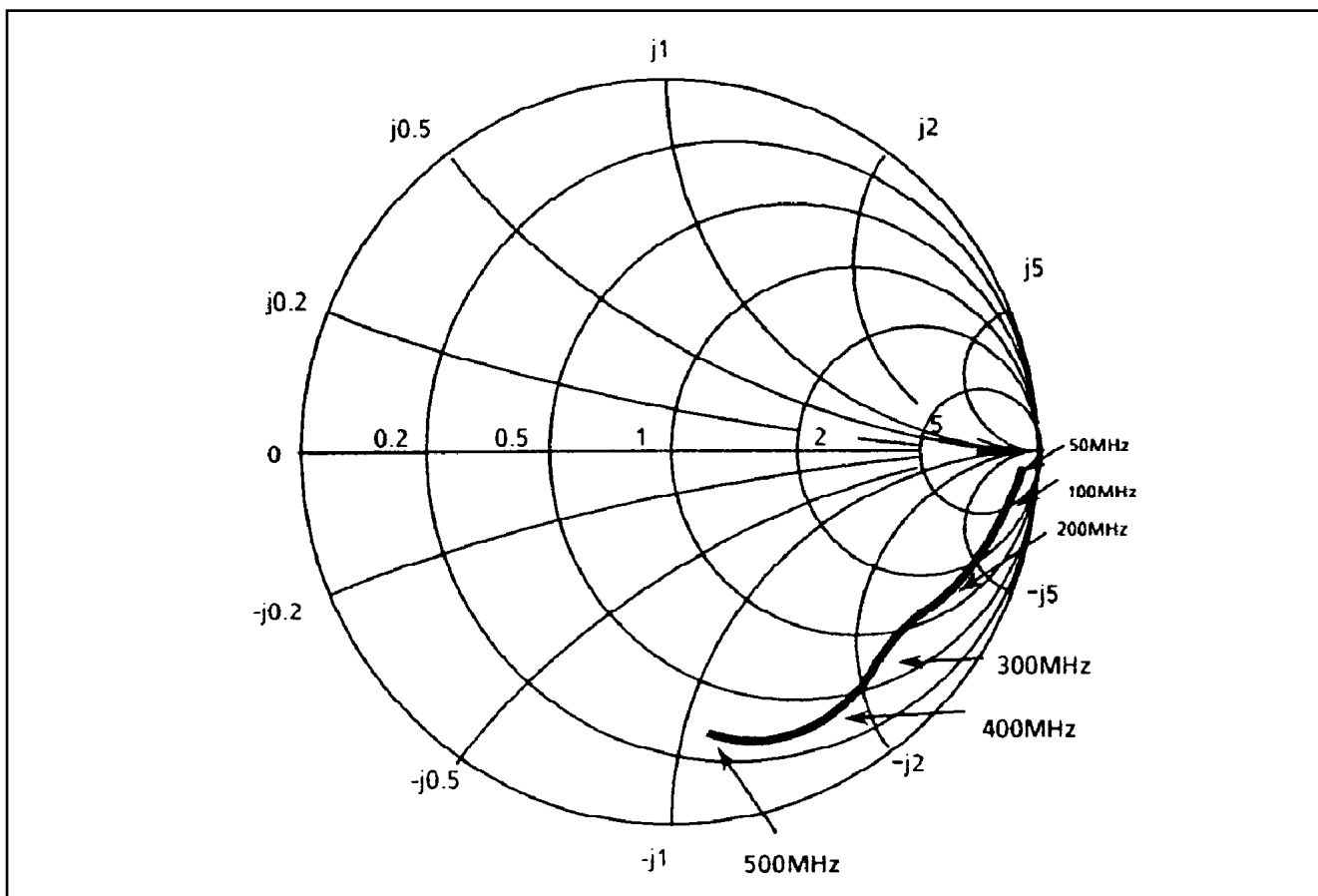

Fig. 7 Input impedance 50 system

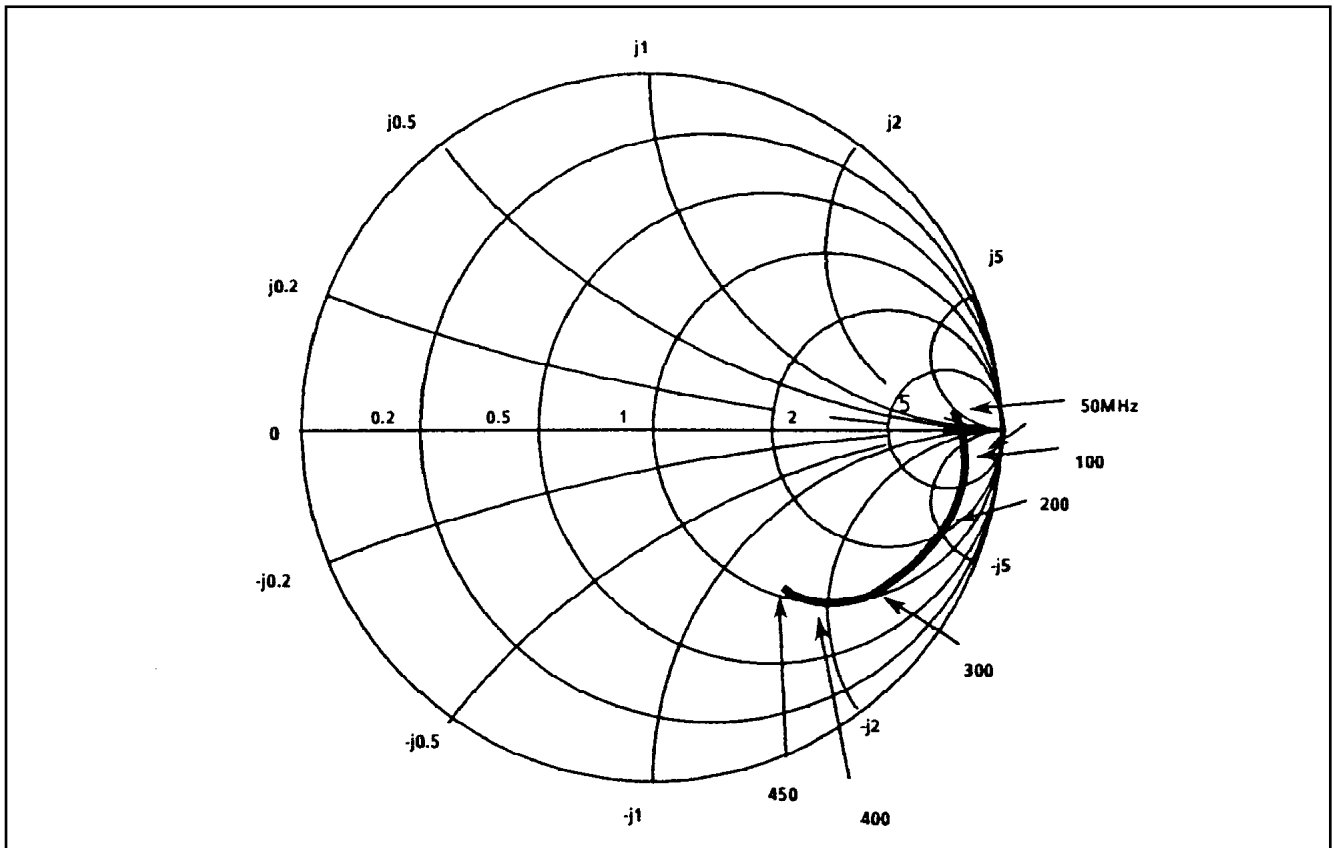

Fig. 8 Output impedance 50 system

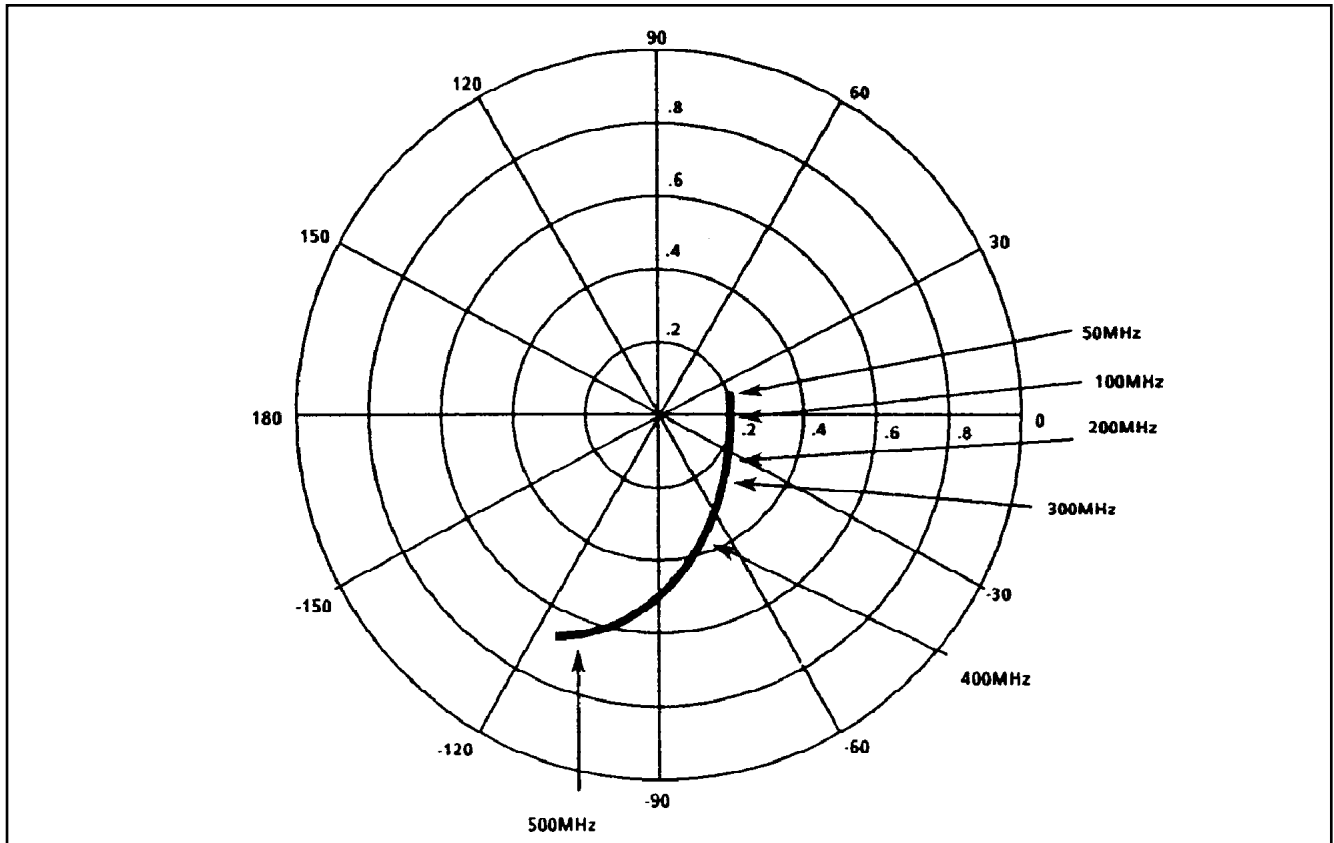

Fig. 9 Reverse transmission coefficient S_{12} SL6140

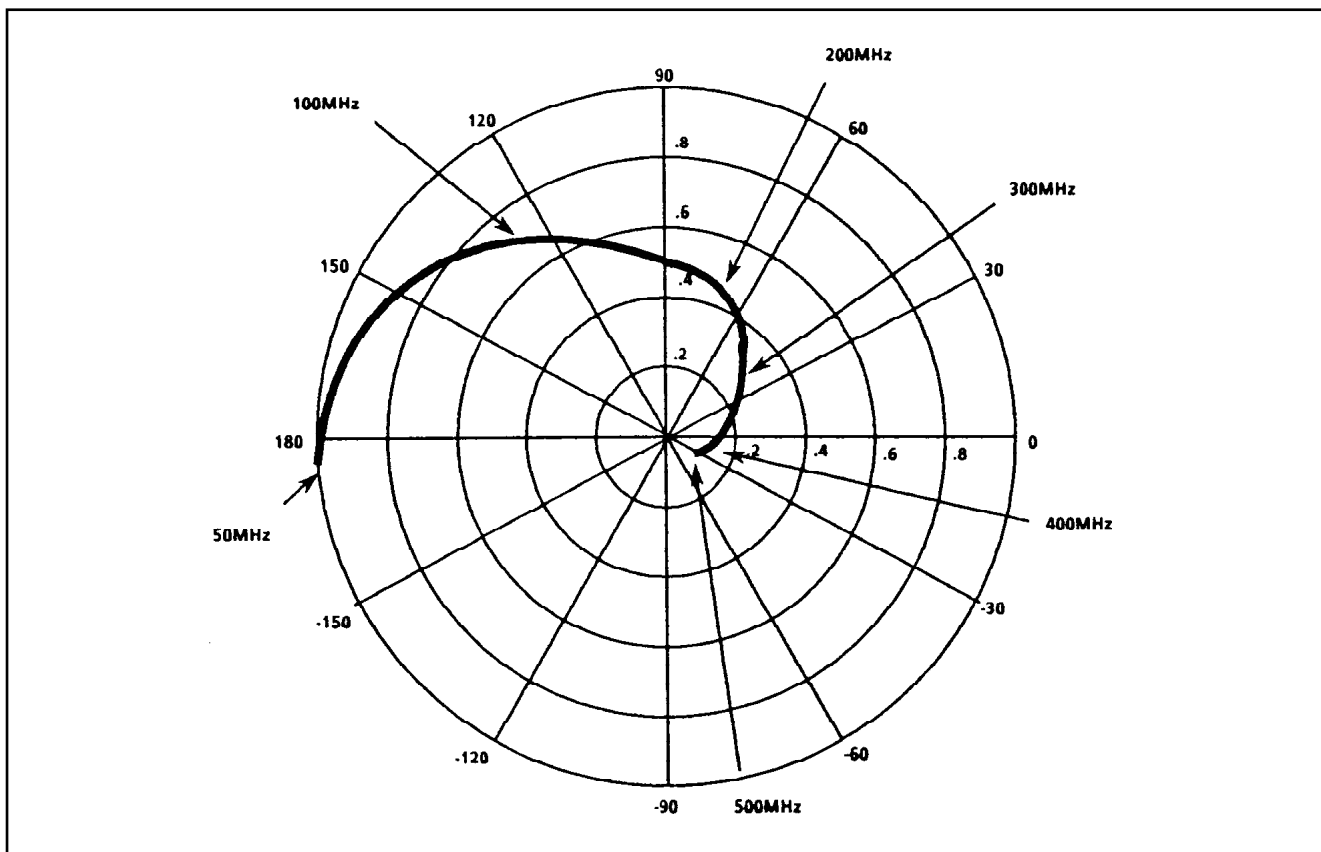

Fig. 10 Forward transmission coefficients S_{21} SL6140

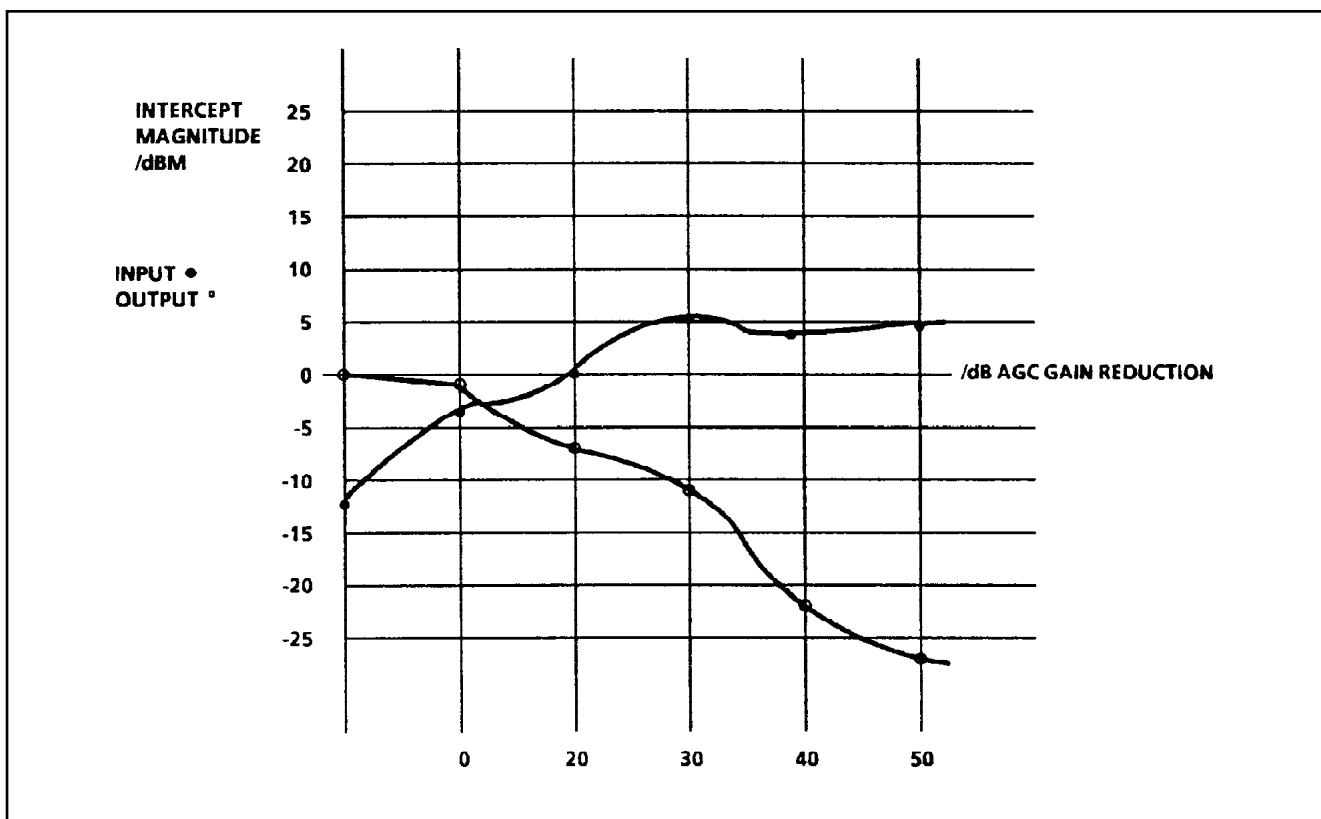

Fig. 11 3rd Order intercept point against gain reduction at 250.0MHz and 254.0MHz

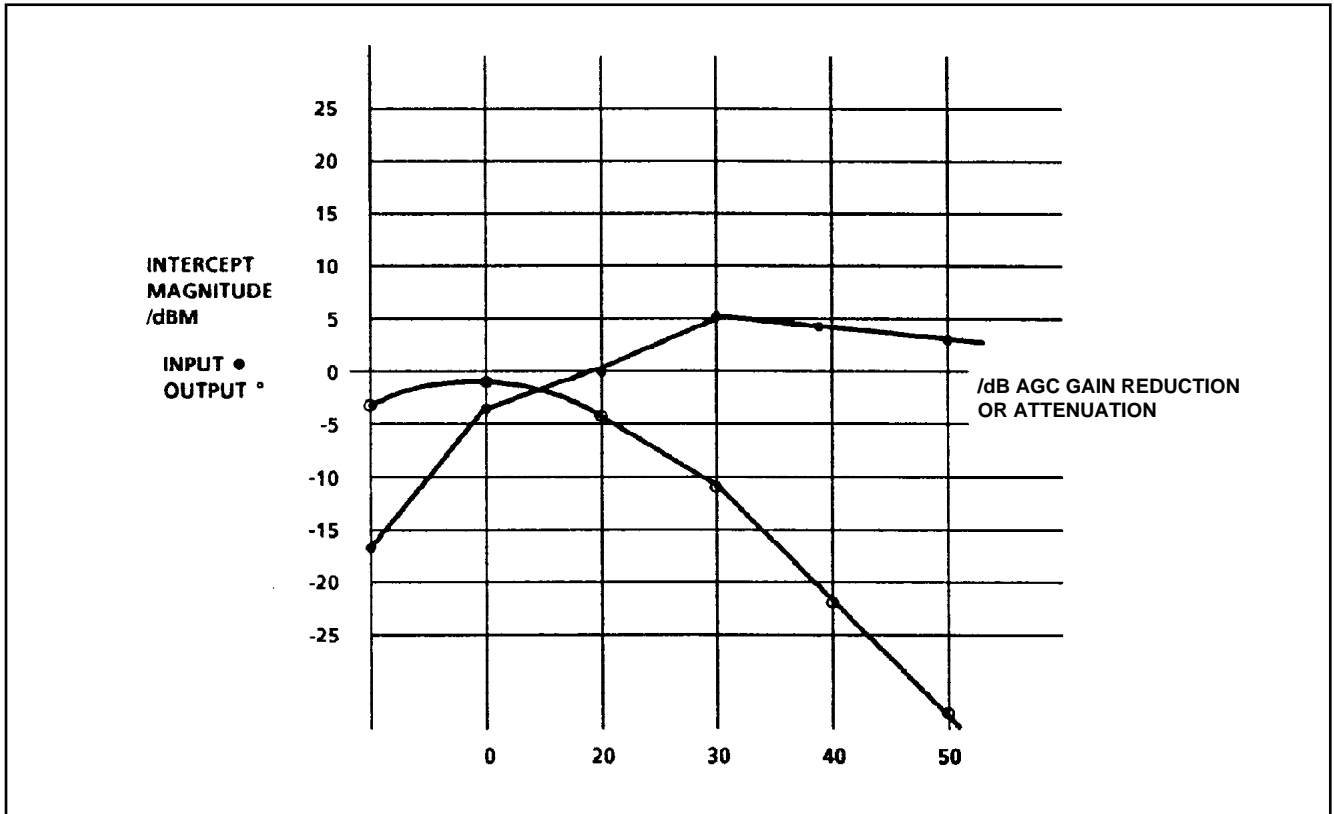

Fig. 12 3rd Order intercept point against gain reduction at 100.0MHz and 104.0MHz

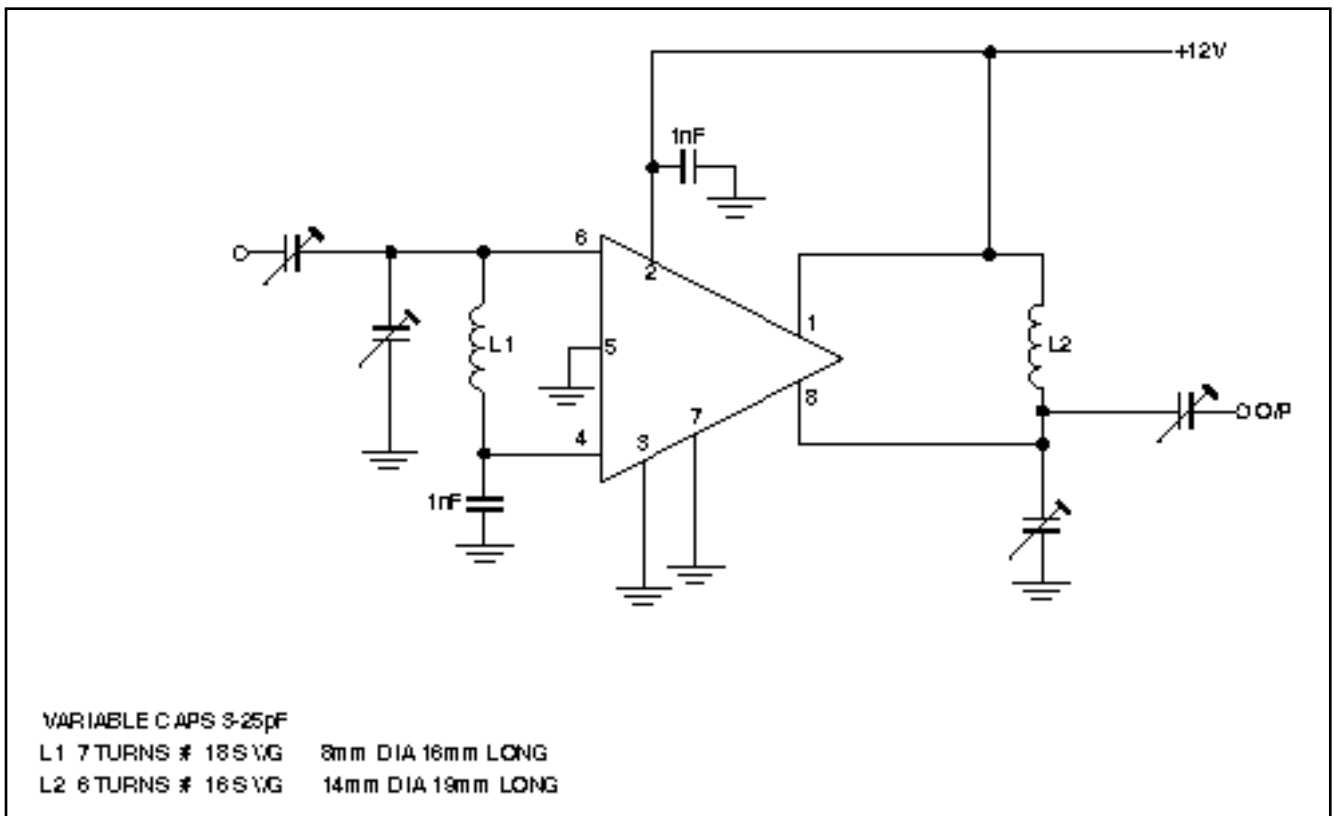

Fig. 13 50MHz Noise figure test circuit

SL6140

SL6140

PACKAGE DETAILS

Dimensions are shown thus: mm (in).

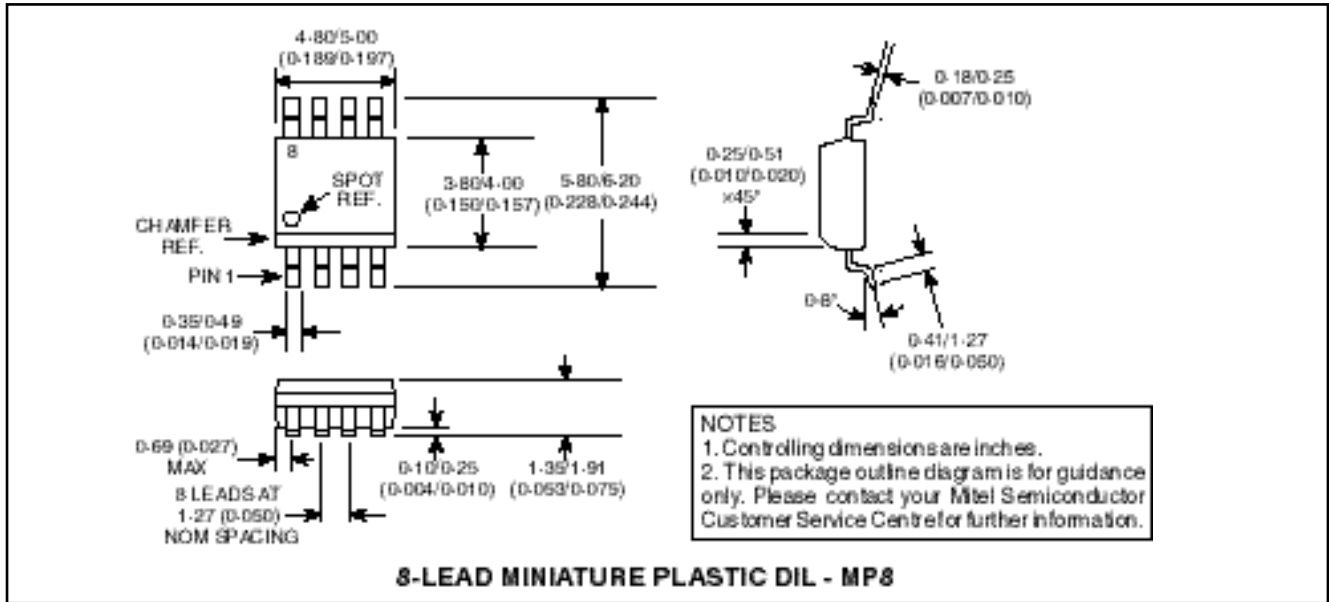

HEADQUARTERS OPERATIONS

MITEL SEMICONDUCTOR

Cheney Manor, Swindon,
Wiltshire SN2 2QW, United Kingdom.
Tel: (01793) 518000
Fax: (01793) 518411

MITEL SEMICONDUCTOR

1500 Green Hills Road,
Scotts Valley, California 95066-4922
United States of America.
Tel (408) 438 2900
Fax: (408) 438 5576/6231

Internet: <http://www.gpsemi.com>

CUSTOMER SERVICE CENTRES

- **FRANCE & BENELUX** Les Ulis Cedex Tel: (1) 69 18 90 00 Fax : (1) 64 46 06 07
- **GERMANY** Munich Tel: (089) 419508-20 Fax : (089) 419508-55
- **ITALY** Milan Tel: (02) 6607151 Fax: (02) 66040993
- **JAPAN** Tokyo Tel: (03) 5276-5501 Fax: (03) 5276-5510
- **KOREA** Seoul Tel: (2) 5668141 Fax: (2) 5697933
- **NORTH AMERICA** Scotts Valley, USA Tel: (408) 438 2900 Fax: (408) 438 5576/6231
- **SOUTH EAST ASIA** Singapore Tel:(65) 3827708 Fax: (65) 3828872
- **SWEDEN** Stockholm Tel: 46 8 702 97 70 Fax: 46 8 640 47 36
- **TAIWAN, ROC** Taipei Tel: 886 2 25461260 Fax: 886 2 27190260
- **UK, EIRE, DENMARK, FINLAND & NORWAY**
Swindon Tel: (01793) 726666 Fax : (01793) 518582

These are supported by Agents and Distributors in major countries world-wide.

© Mitel Corporation 1998 Publication No. DS2159 Issue No. 4.1 October 1995

TECHNICAL DOCUMENTATION – NOT FOR RESALE. PRINTED IN UNITED KINGDOM

This publication is issued to provide information only which (unless agreed by the Company in writing) may not be used, applied or reproduced for any purpose nor form part of any order or contract nor to be regarded as a representation relating to the products or services concerned. No warranty or guarantee express or implied is made regarding the capability, performance or suitability of any product or service. The Company reserves the right to alter without prior notice the specification, design or price of any product or service. Information concerning possible methods of use is provided as a guide only and does not constitute any guarantee that such methods of use will be satisfactory in a specific piece of equipment. It is the user's responsibility to fully determine the performance and suitability of any equipment using such information and to ensure that any publication or data used is up to date and has not been superseded. These products are not suitable for use in any medical products whose failure to perform may result in significant injury or death to the user. All products and materials are sold and services provided subject to the Company's conditions of sale, which are available on request.

All brand names and product names used in this publication are trademarks, registered trademarks or trade names of their respective owners.